

draughting/drafting conventions (GB/ US)

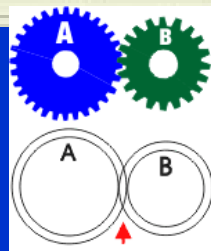
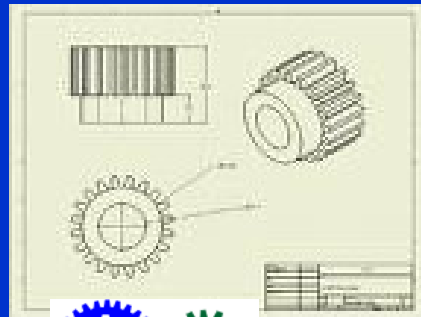
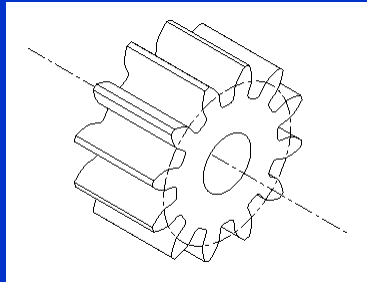

TD_06

1

simplifying: small or complex

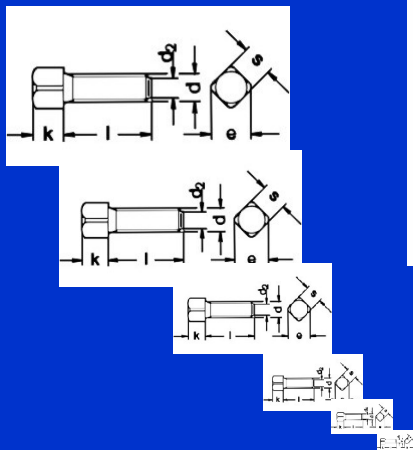

TD_06

2

threads

- major dia. = **névleges átmérő**
- pitch dia. = **középátmérő**
- minor dia. = **magátmérő**
- pitch = **menetemelkedés**
- **Section (vee or...)**
- **L/R hand**
- **Single/ multiple thread**
(lead = $n \times$ pitch)

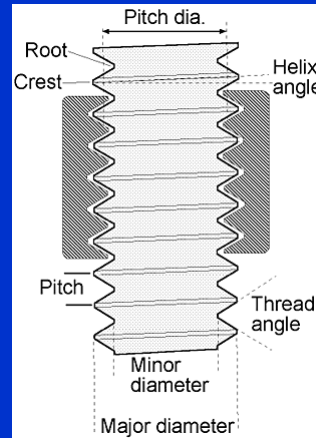

TD_06

3

Thread types

Vee section:

- ISO metric
- Whitworth
- Pipe
 - (BSPP, BSPT parallel/ tapered)
- Unified (GB,US,CAN)
 - UNC, UNF (coarse/ fine)
- ACME power thread (trapezium/ trapezoid)
- knuckle

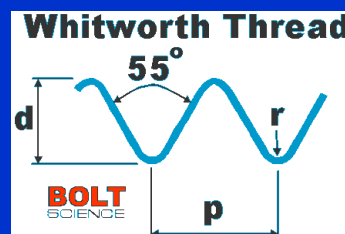
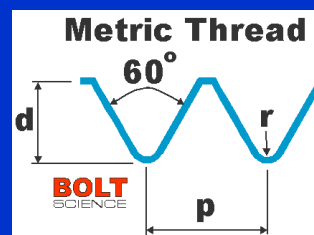

TD_06

4

dimensioning

- section symbol, nominal size (xpitch...)
- M10 normal
- M10x0.5 fine
- M20x1(P2) LH .. Fine, multiple, LH
- G 11 pipe thread „másfél colos”
-
- E 14, E27 Edison thread

TD_06

5

representation

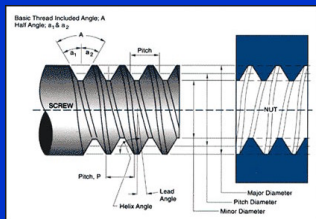

male - female

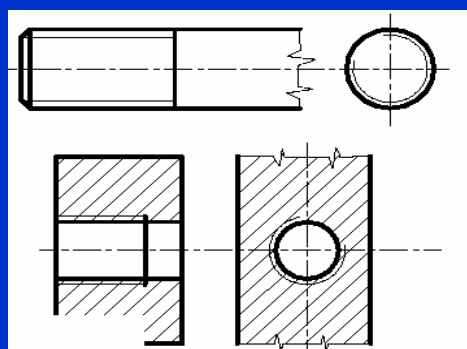
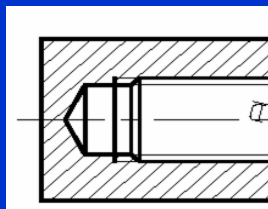

convention by production
(from rod/ by tapping drill)

TD_06

6

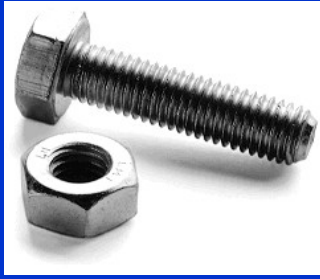

more threads...

nut + bolt
washer
screw (set ~,...)

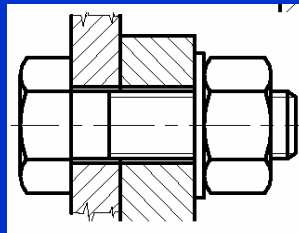
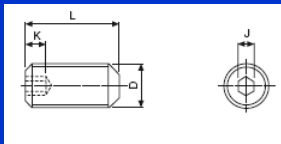
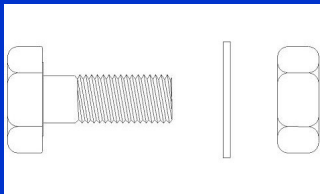

TD_06

7

gear representation

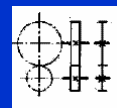
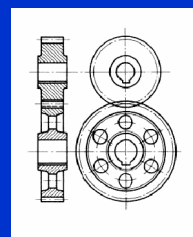
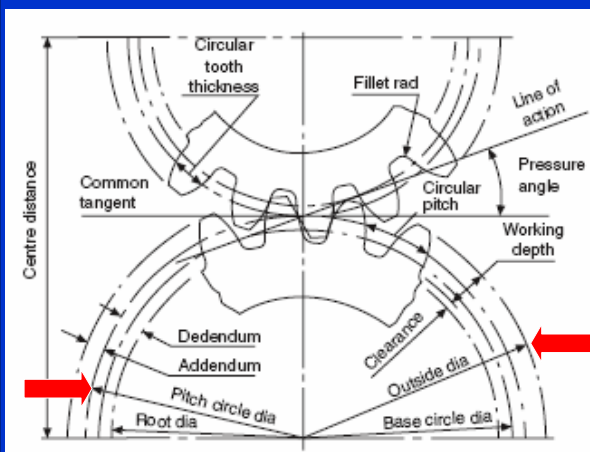

sketch symbol

TD_06

8

other serrated/toothed elements

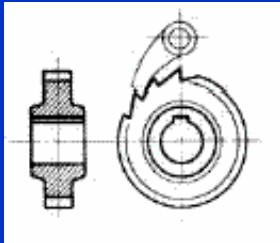

ratchet wheel

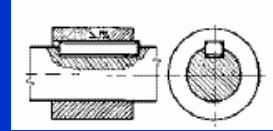

key

splined shaft/ hub

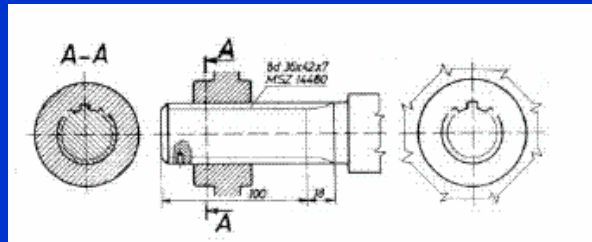

TD_06

9

rolling bearings

simplified

symbolic

standard

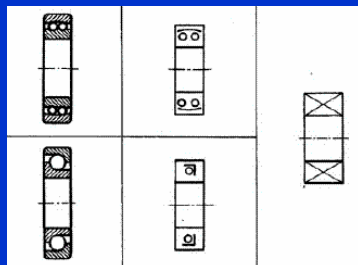

TD_06

10

springs

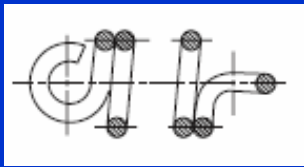
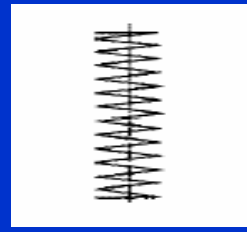
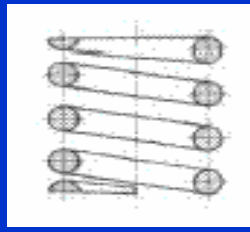
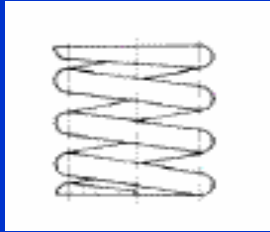

helical compression springs

extension ~

characteristic

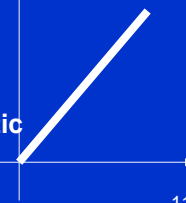

TD_06

11

technical english

TD_06

12



rosie the riveter

WW2



TD_06

13



feel the difference

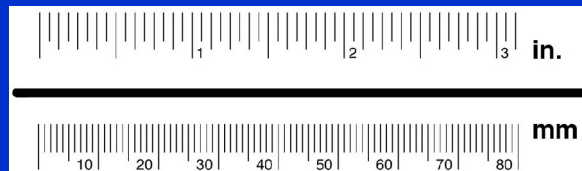
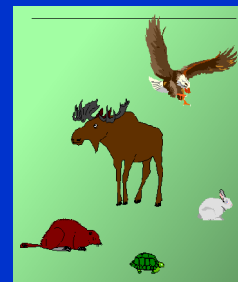

TD_06

14

differences, differences...1.



no joke, russian college →



TD_06

15

differences, differences...2

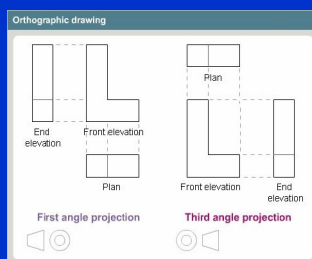

British convention +Europe...	American convention + Russia, Asia...
3rd floor	4th floor
2nd floor	3rd floor
1st floor	2nd floor
<u>Ground floor</u>	Ground or 1st floor

TD_06

16

Isometric exercise

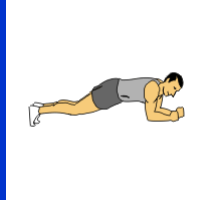

Draw 1st and 3rd angle views on 5 mm plain grid
„kockás papír”
(FRT)

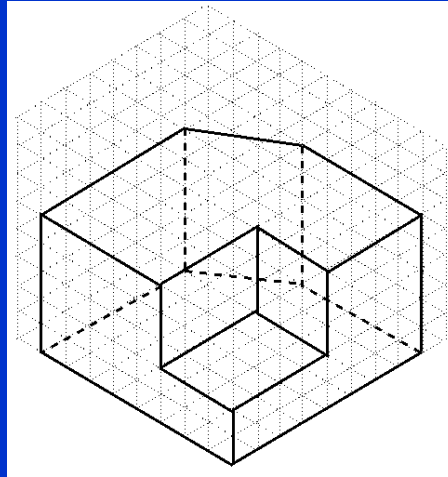

Homework

TD_06

17

Three orthogonal views

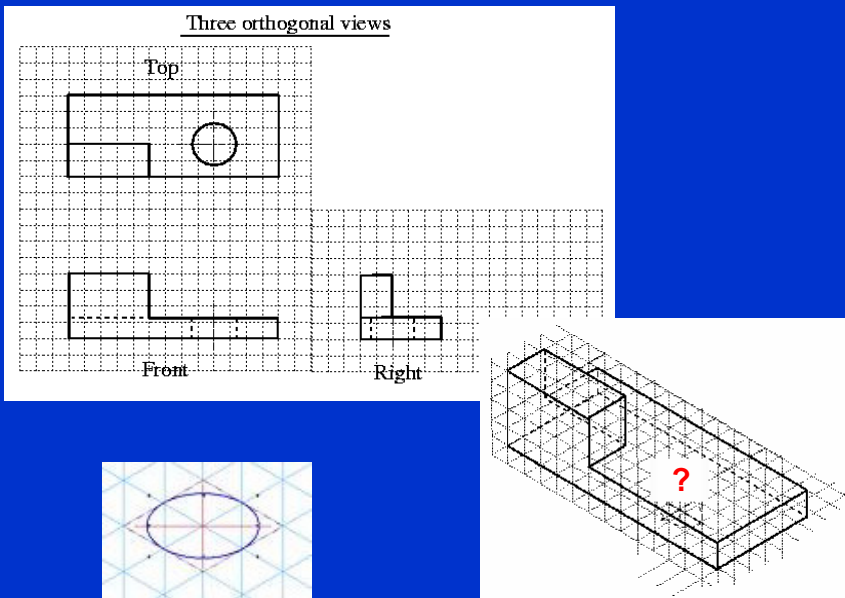

TD_06

18

Homework

Nearest edge

TD_06

19